

# TB6612FNG Dual Motor Driver Carrier

## Overview

The [TB6612FNG](#) (207k pdf) is a great dual motor driver that is perfect for interfacing two small DC motors such as our [micro metal gearmotors](#) to a microcontroller, and it can also be used to control a single [bipolar stepper motor](#). The MOSFET-based H-bridges are much more efficient than the BJT-based H-bridges used in older drivers such as the [L298N](#) and Sanyo's [LB1836M](#), which allows more current to be delivered to the motors and less to be drawn from the logic supply (the LB1836 still has the TB6612 beat for really low-voltage applications). Our little breakout board gives you direct access to all of the features of the TB6612FNG and adds power supply capacitors and reverse battery protection on the motor supply (note: there is no reverse protection on the Vcc connection).

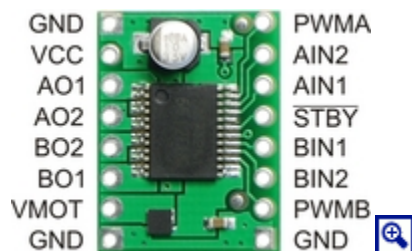

In a typical application, power connections are made on one side of the board and control connections are made on the other. All of the control inputs are internally pulled low. Each of the two motor channels has two direction control pins and a speed control pin that accepts a PWM input with a frequency of up to 100 kHz. The STBY pin must be driven high to take the driver out of standby mode.

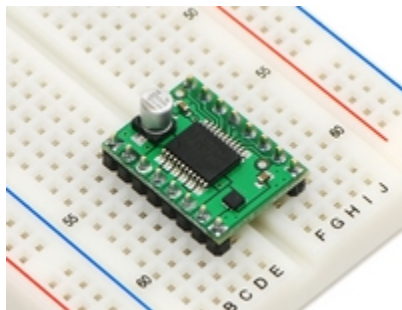

**TB6612FNG dual motor driver carrier on a breadboard.**

The distance between the header rows on the PCB is 0.1" smaller than a standard 0.6" DIP package (e.g. the [Baby Orangutan](#)), but the pin spacing allows it to conveniently fit in 0.1" breadboards and perfboards.

For a more advanced motor controller based on this driver, please consider the [qik 2s9v1](#) dual serial motor controller. For a robot controller based on this driver, please consider the [Baby Orangutan](#), [Orangutan SV-328](#), [Orangutan SVP-324](#), and [3pi robot](#), which connect the TB6612 to a user-programmable AVR microcontroller.

## TB6612 Specifications

- Recommended motor voltage (VMOT): 4.5 – 13.5 V
- Logic voltage (VCC): 2.7 – 5.5 V
- Output current maximum: 3 A per channel
- Output current continuous: 1 A per channel (can be paralleled to deliver 2 A continuous)
- Maximum PWM frequency: 100 kHz
- Built-in thermal shutdown circuit
- Filtering capacitors on both supply lines
- Reverse-power protection on the motor supply

## Real-world power dissipation considerations

The TB6612 motor driver used on the carrier board has a peak current rating of 3 A per channel. The peak ratings are for quick transients (e.g. when a motor is first turned on), and the continuous rating of 1 A is dependent on various conditions, such as the ambient temperature. The actual current you can deliver will depend on how well you can keep the motor driver cool. The carrier's printed circuit board is designed to draw heat out of the motor driver chip, but performance can be improved by adding a heat sink.

## Schematic Diagram

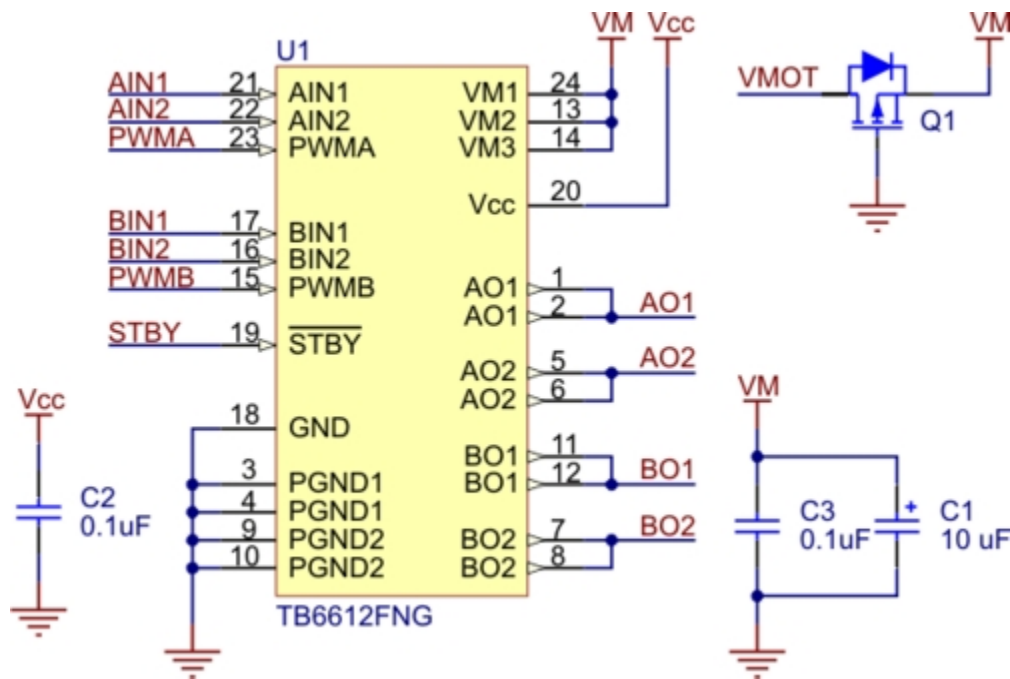

**Note:** 16 male header pins are included but not soldered onto the boards. No printed documentation is shipped with these items; please see the TB6612FNG datasheet in the resources tab for more information about the motor driver.